



UNIVERSITY OF CAMBRIDGE INTERNATIONAL EXAMINATIONS
International General Certificate of Secondary Education

CANDIDATE
NAME

CENTRE
NUMBER

--	--	--	--	--

CANDIDATE
NUMBER

--	--	--	--	--

CAMBRIDGE INTERNATIONAL MATHEMATICS

0607/32

Paper 3 (Core)

May/June 2013

1 hour 45 minutes

Candidates answer on the Question Paper.

Additional Materials: Geometrical Instruments
 Graphics Calculator

READ THESE INSTRUCTIONS FIRST

Write your Centre number, candidate number and name on all the work you hand in.

Write in dark blue or black pen.

Do not use staples, paper clips, highlighters, glue or correction fluid.

You may use a pencil for any diagrams or graphs.

DO NOT WRITE IN ANY BARCODES.

Answer **all** the questions.

Unless instructed otherwise, give your answers exactly or correct to three significant figures as appropriate.

Answers in degrees should be given to one decimal place.

For π , use your calculator value.

You must show all the relevant working to gain full marks and you will be given marks for correct methods, including sketches, even if your answer is incorrect.

The number of marks is given in brackets [] at the end of each question or part question.

The total number of marks for this paper is 96.

This document consists of **16** printed pages.



Formula List

Area, A , of triangle, base b , height h .	$A = \frac{1}{2}bh$
Area, A , of circle, radius r .	$A = \pi r^2$
Circumference, C , of circle, radius r .	$C = 2\pi r$
Curved surface area, A , of cylinder of radius r , height h .	$A = 2\pi rh$
Curved surface area, A , of cone of radius r , sloping edge l .	$A = \pi rl$
Curved surface area, A , of sphere of radius r .	$A = 4\pi r^2$
Volume, V , of prism, cross-sectional area A , length l .	$V = Al$
Volume, V , of pyramid, base area A , height h .	$V = \frac{1}{3}Ah$
Volume, V , of cylinder of radius r , height h .	$V = \pi r^2 h$
Volume, V , of cone of radius r , height h .	$V = \frac{1}{3}\pi r^2 h$
Volume, V , of sphere of radius r .	$V = \frac{4}{3}\pi r^3$

Answer **all** the questions.

For
Examiner's
Use

1 A jar is filled with 120 cream toffees, 90 liquorice toffees and 60 chocolate toffees.

(a) How many more cream toffees are there than liquorice toffees?

Answer(a) [1]

(b) Find the total number of toffees in the jar.

Answer(b) [1]

(c) One toffee is chosen at random.

Find the probability that it is

(i) a liquorice toffee,

Answer(c)(i) [1]

(ii) **not** a cream toffee,

Answer(c)(ii) [1]

(iii) a mint toffee.

Answer(c)(iii) [1]

(d) Sid is 14 years old, Ren is 15 years old and Tarrik is 16 years old.
They share all the toffees in the ratio of their ages.

Calculate the number of toffees that Ren receives.

Answer(d) [2]

- 2 Fifteen children were each given a different number of equations to solve. The number of equations solved and the time taken to solve them, to the nearest second, are shown in the table.

For
Examiner's
Use

Number of equations	3	4	6	9	10	11	12	14	15	17	20	21	22	25	30
Time (seconds)	8	11	12	20	21	34	28	40	41	45	60	58	61	70	82

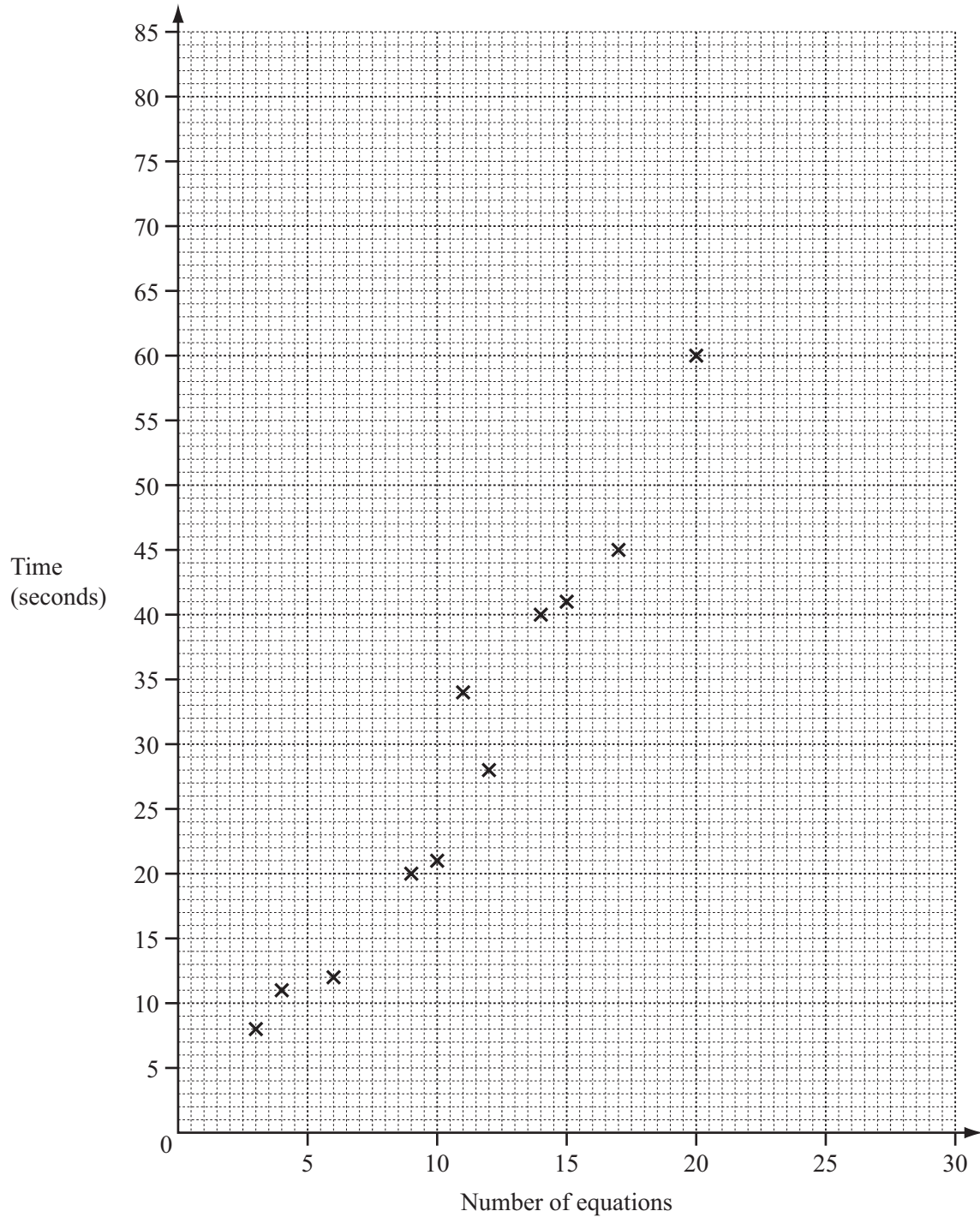

- (a) Complete the scatter diagram.
The first eleven points have been plotted for you.

[2]

(b) Describe the type of correlation.

Answer(b) [1]

(c) (i) Find the mean number of equations solved.

Answer(c)(i) [1]

(ii) Find the mean time taken.

Answer(c)(ii) s [1]

(iii) On the diagram, plot the mean point. [1]

(d) On the diagram, draw the line of best fit by eye. [2]

(e) Use your line of best fit to estimate the time taken to solve 8 equations.

Answer(e) s [1]

For
Examiner's
Use

- 3 Yana and Jelle are arranging a party.
The cost of one packet of crisps is $\$c$ and the cost of one bottle of juice is $\$j$.

Yana spends a total of $\$10$ on 12 packets of crisps and 5 bottles of juice.
Jelle spends a total of $\$11$ on 6 packets of crisps and 10 bottles of juice.

- (a) Write down two equations in c and j to show this information.

Answer(a)
..... [2]

- (b) Find the cost of one packet of crisps and the cost of one bottle of juice.

Answer(b) crisps $\$$
juice $\$$ [3]

- 4 A bean plant grows at a constant rate.
The table shows its height above the ground each day.

Day	1	2	3	4	5
Height above ground (h cm)	1	3	5		

- (a) Complete the table. [2]
- (b) Find an expression, in terms of n , for the height of the bean plant after n days.

Answer(b) [2]

- (c) Calculate the number of days it takes for the bean plant to reach a height of 83 cm.

Answer(c) days [2]

5

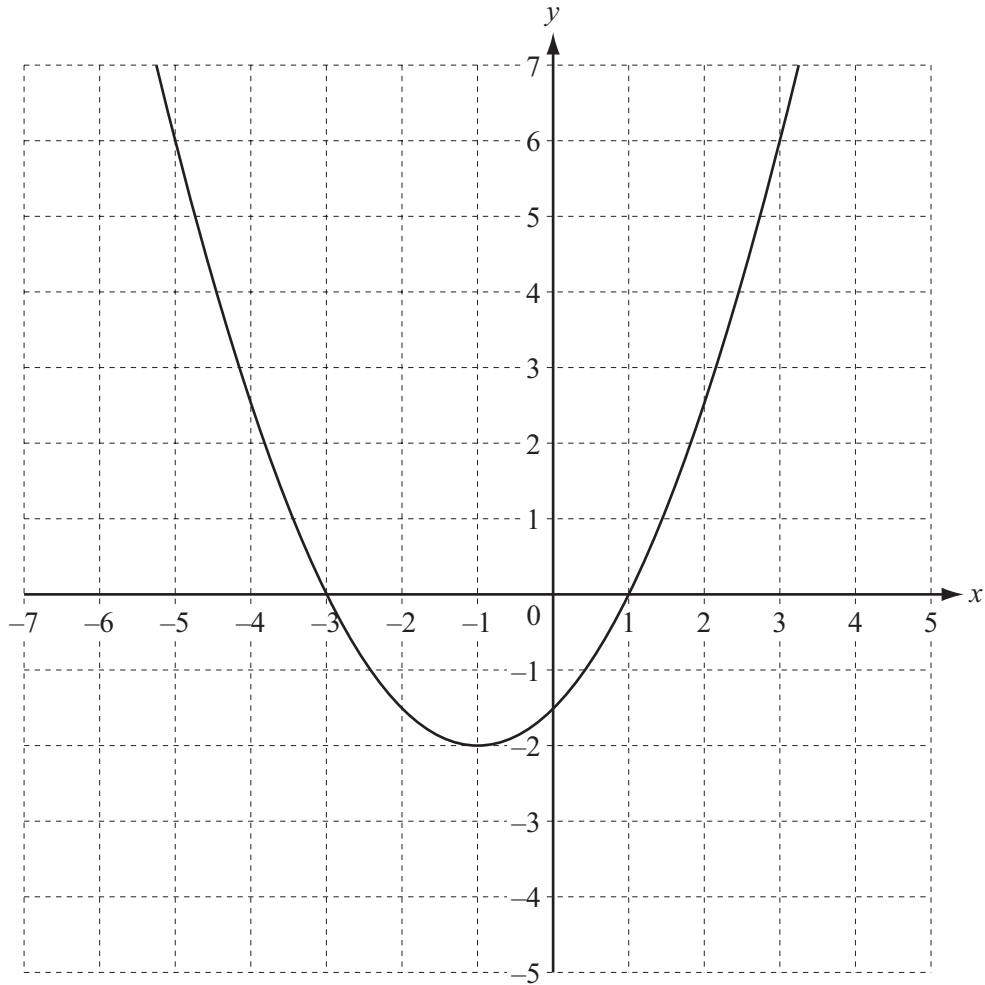
For
Examiner's
Use

The diagram shows the graph of $y = f(x)$.

(a) Write down the zeros of $y = f(x)$.

Answer(a) and [2]

(b) On the same diagram, sketch the graphs of

$$y = f(x) - 3,$$

$$\text{and } y = f(x + 2).$$

[2]

6

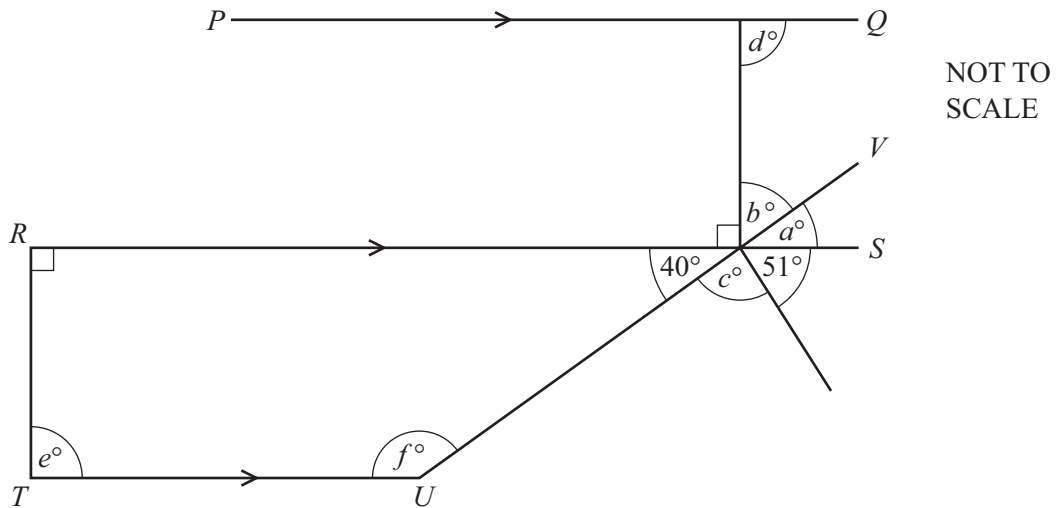
For
Examiner's
Use

PQ , RS and TU are parallel lines and UV is a straight line.

Find the values of a , b , c , d , e and f .

Answer $a =$

$b =$

$c =$

$d =$

$e =$

$f =$ [6]

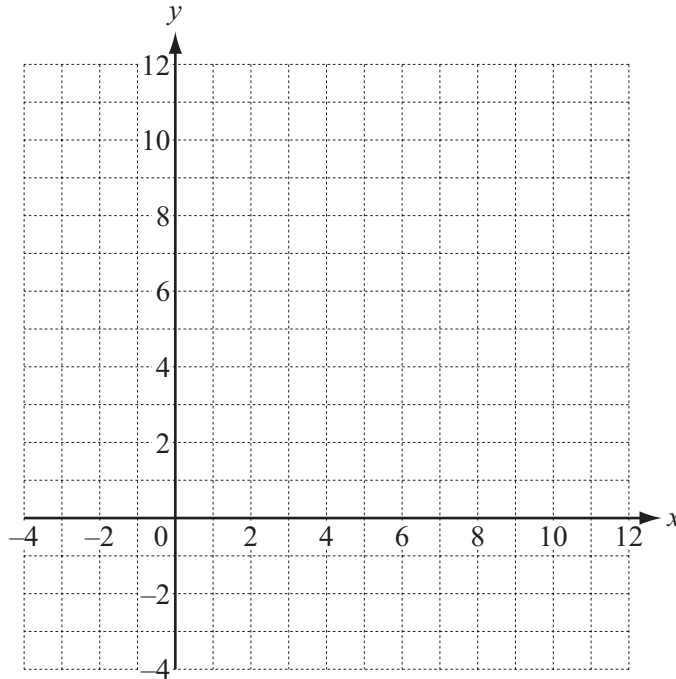

(a) On the grid, plot the points $A(1, 9)$ and $B(7, -3)$. [2]

(b) Write down \vec{AB} in component form.

Answer(b) $\left(\begin{array}{c} \\ \end{array} \right)$ [1]

(c) Find the co-ordinates of the midpoint of AB .

Answer(c) (..... ,) [1]

(d) Calculate the length of AB .

Answer(d) [2]

(e) Calculate the gradient of AB .

Answer(e) [2]

(f) Find the equation of the line passing through the points A and B .
Give your answer in the form $y = mx + c$.

Answer(f) $y =$ [2]

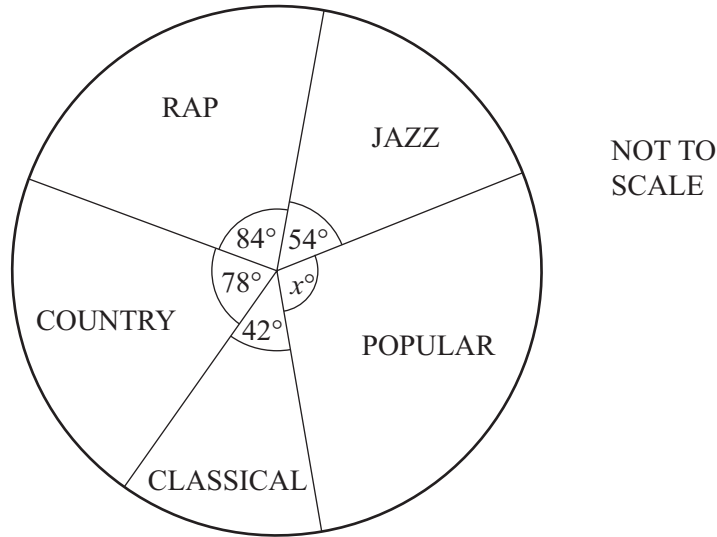

Rita asked 60 students what type of music they liked best.
The pie chart shows her results.

(a) Find the value of x .

Answer(a) [1]

(b) Calculate the number of students who like **rap** best.

Answer(b) [2]

(c) One of the students is chosen at random.
Find the probability that this student liked **jazz** best.

Answer(c) [1]

- 9 $U = \{a, b, c, d, e, f, g, h\}$
 $A = \{c, e, g\}$
 $B = \{f, g, h\}$

(a) Complete the Venn diagram.

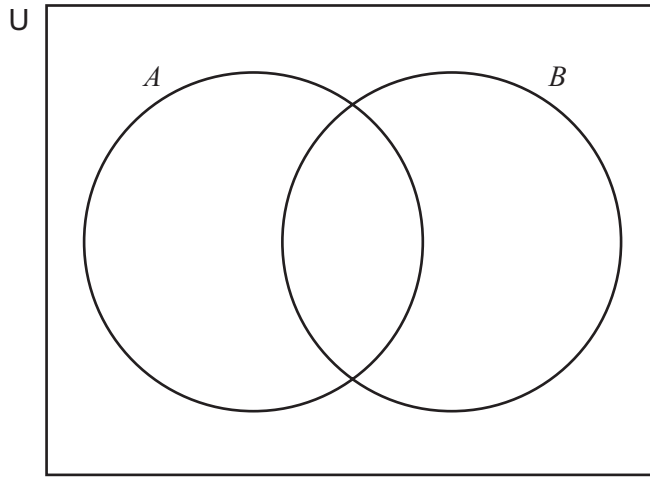

[2]

(b) List the elements of the following sets.

(i) $A \cup B$

Answer(b)(i) [1]

(ii) B'

Answer(b)(ii) [1]

(iii) $A \cap B$

Answer(b)(iii) [1]

(iv) $A \cup B'$

Answer(b)(iv) [1]

(c) Write down $n(A \cup B)$.

Answer(c) [1]

10

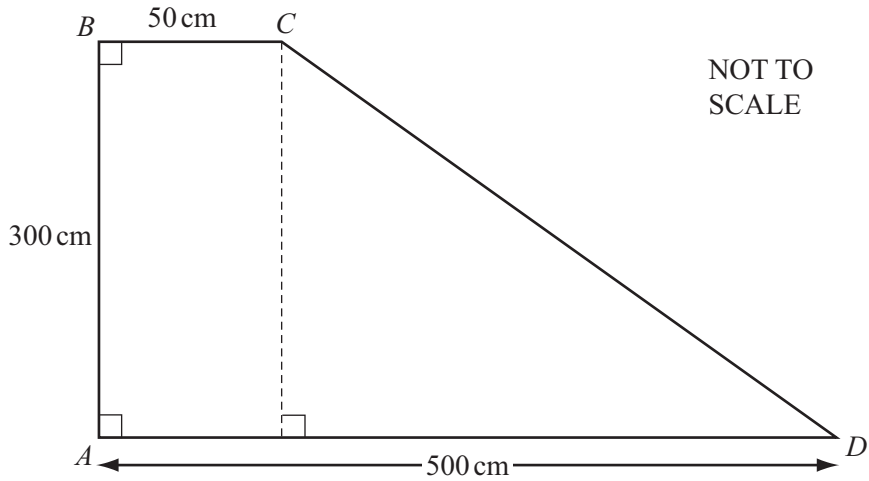

For
Examiner's
Use

The diagram shows the side view of a child's slide, $ABCD$.

(a) Calculate CD .

Answer(a) cm [3]

(b) Use trigonometry to find the size of angle CDA .

Answer(b) [2]

(c) Tayaab takes 3 seconds to slide from C to D .
Calculate his speed in **metres per minute**.

Answer(c) m/min [3]

11

For
Examiner's
Use

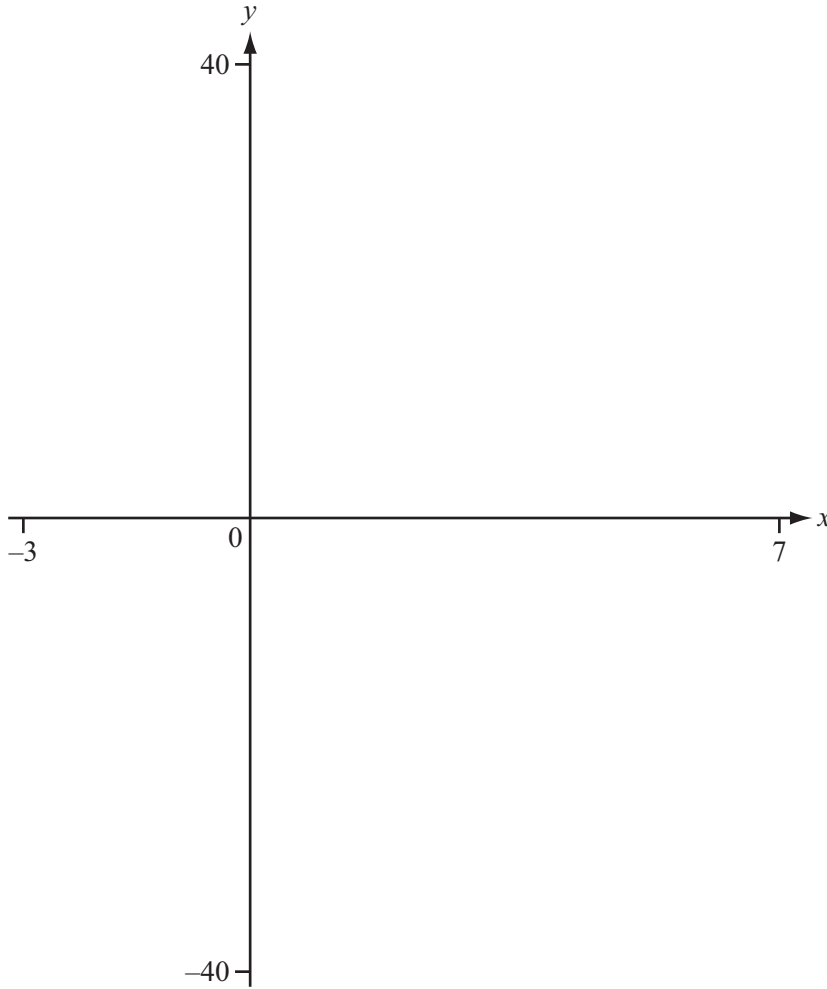

(a) On the diagram, sketch the graph of $y = x^3 - 5x^2 - 8x + 12$. [2]

(b) Find the co-ordinates of the local maximum and the local minimum points.

Answer(b) (..... ,)

(..... ,) [2]

(c) On the same diagram sketch the graph of $y = 2x + 3$. [1]

(d) Find the x co-ordinates of the points where the two graphs intersect.

Answer(d) $x =$

or $x =$

or $x =$ [3]

12

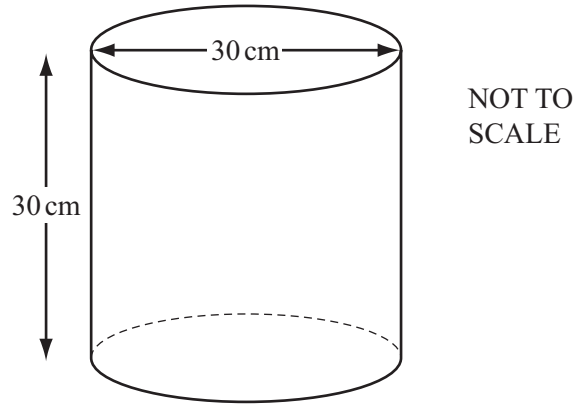

For
Examiner's
Use

A closed cylinder has a diameter of 30 cm and a height of 30 cm.

(a) (i) Find the **total** surface area of the cylinder.

Answer(a)(i) cm^2 [3]

(ii) Find the volume of the cylinder.

Answer(a)(ii) cm^3 [2]

(b) The cylinder contains a sphere of radius 15 cm.

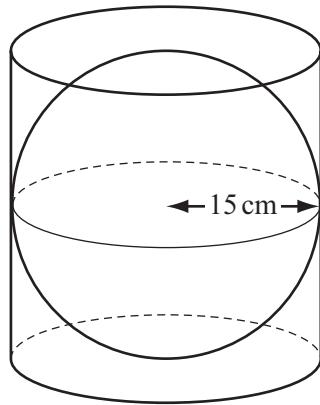

NOT TO
SCALE

For
Examiner's
Use

(i) Find the volume of this sphere.

Answer(b)(i) cm³ [2]

(ii) Find the percentage of the volume of the cylinder that is **not** taken up by the sphere.

Answer(b)(ii) % [3]

Question 13 is printed on the next page.

13 (a) Expand and simplify.

$$(x - 2)(2x + 3)$$

Answer(a) [2]

(b) Factorise completely.

$$10x^2 - 15x$$

Answer(b) [2]

(c) Simplify fully the following expressions.

(i) $\frac{8xy^2}{2y}$

Answer(c)(i) [2]

(ii) $\frac{9s}{5t} \div \frac{3}{10t}$

Answer(c)(ii) [2]

(iii) $\frac{3p}{4} - \frac{2p}{3}$

Answer(c)(iii) [2]

(iv) $(2y^2)^3$

Answer(c)(iv) [2]

Permission to reproduce items where third-party owned material protected by copyright is included has been sought and cleared where possible. Every reasonable effort has been made by the publisher (UCLES) to trace copyright holders, but if any items requiring clearance have unwittingly been included, the publisher will be pleased to make amends at the earliest possible opportunity.

University of Cambridge International Examinations is part of the Cambridge Assessment Group. Cambridge Assessment is the brand name of University of Cambridge Local Examinations Syndicate (UCLES), which is itself a department of the University of Cambridge.